

4.0T Electrical Lock Release 2-Post Lift

QSD4000A



Electric Lock Release
电动解锁



Electromagnetic Lowering
电磁下降

QSD3800



Electric Lock Release
电动解锁



Electromagnetic Lowering
电磁下降



OPTIONAL ACCESSORIES 可选配件



Height adapters for suvs & trucks (50/70/100mm)
适用于各种车型的增高套



Anti-dust column cap (QSD4000A)
立柱防尘装饰帽 (QSD4000A)

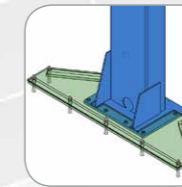

Floor reinforcement
加强底座降低打孔深度

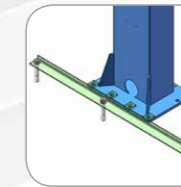

Ground support frames
地板固定横担



Special fork for battery car
电动车托胎器



Fast adjustable pad
快速托盘

OVERALL DIMENSION 尺寸参数

QSD4000A

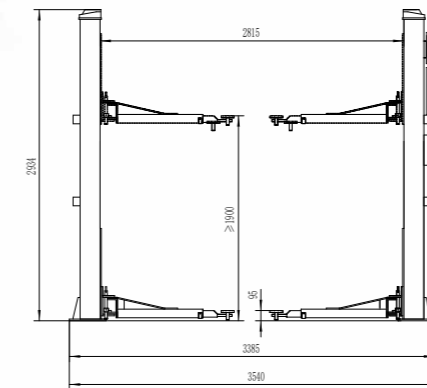

QSD3800

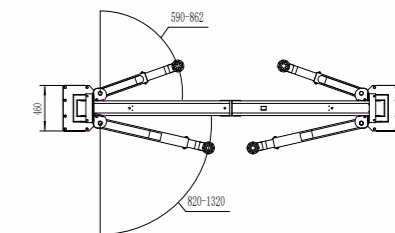
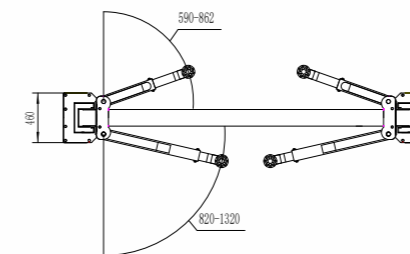
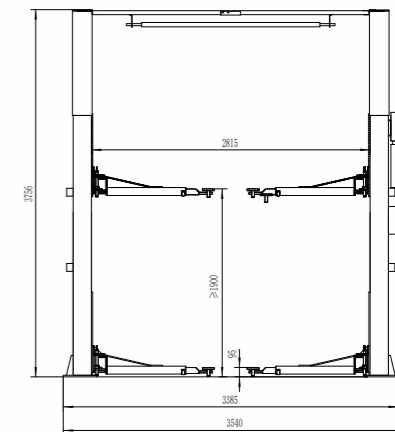

FEATURES 产品特点



Automatic arm-locking system
托臂锁自动上锁设计



Chain protector
链条防脱装置



Synchronization cable
钢丝绳同步



Car door protection
车门防撞垫



24v safety control box
24v 安全操作电控箱



Safety valves against hose breaking
安全阀确保使用安全

STANDARD 标准配置



Adjustable lifting pad
可调节举升托盘



Aluminum motor
铝电机散热性能好



Dust protection pad
防尘遮布

OPTIONAL FEATURES 此产品可选升级方案



3-stage front arms (690mm-1290mm)
3 段式前托臂 (690mm-1290mm)



Adjustable lifting pad to 3 heights
可调节双螺旋 (3 节) 举升托盘

TECHNICAL DATA 技术参数

Model	型号	QSD4000A	QSD3800
Capacity	举升重量	4000kg	4000kg
Lifting height	举升高度	1900mm	1900mm
Min. Height	最低高度	95mm	95mm
Overall height	总高度	2856mm	3756mm/4000mm/4500mm
Overall width	总宽度	3385mm	3385mm
Front arm(2-stage)	前托臂 (2 段式)	590-862mm	590-862mm
Rear arm(2-stage)	后托臂 (2 段式)	820-1320mm	820-1320mm
Lifting time	上升时间	45-50s	45-50s
Power of motor	电机功率	2.2kW	2.2kW